

# **NICROX S250 FLEX**

## **User Manual**

### **Folding Electric Scooter**

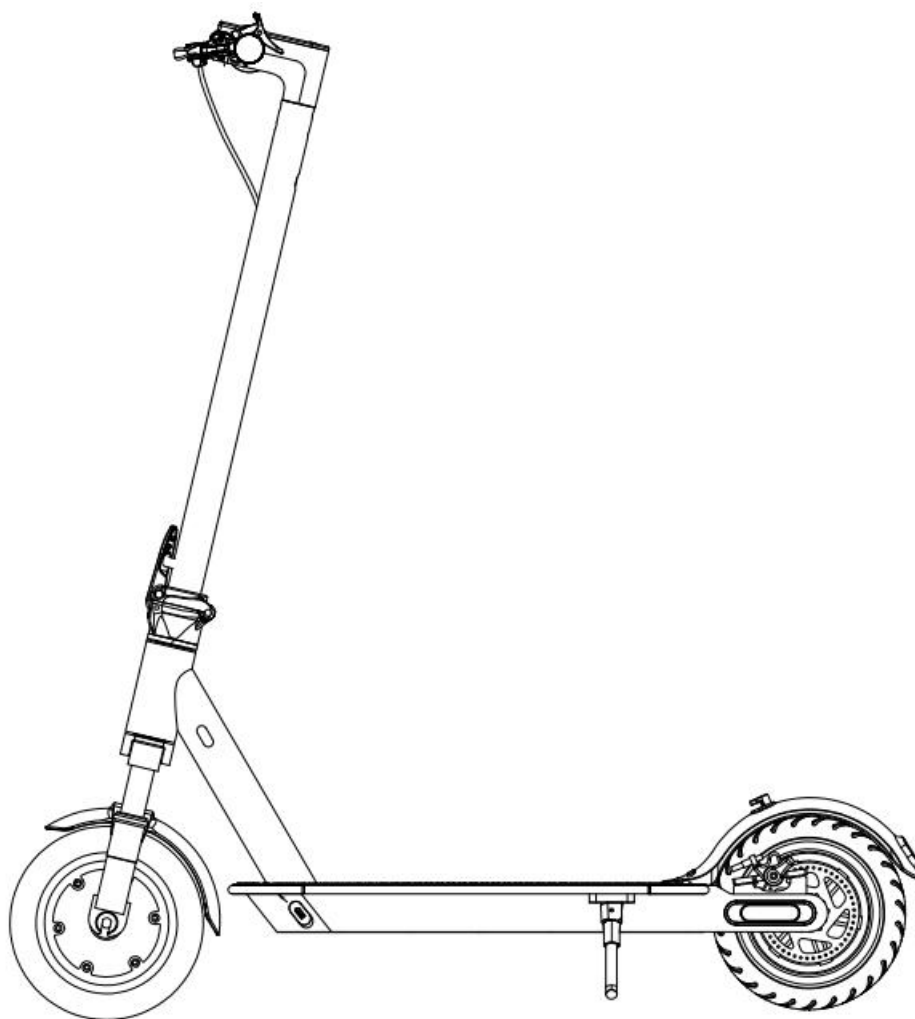

Thanks for choosing our product. Have fun with this electric scooter.

## Contents

1. The Device& Accessories .....	02
2. Functions .....	03
3. Assembling .....	04
4. Charging .....	05
5. Driving Instructions.....	05
6. Safety Recommendations .....	07
7. Folding & Transportation .....	09
8. Daily Maintenance and Storage.....	10
9.Remove Inner and Outer Tires.....	12
10.Specifications .....	13

# 1 The Device & Accessories

Vehicle

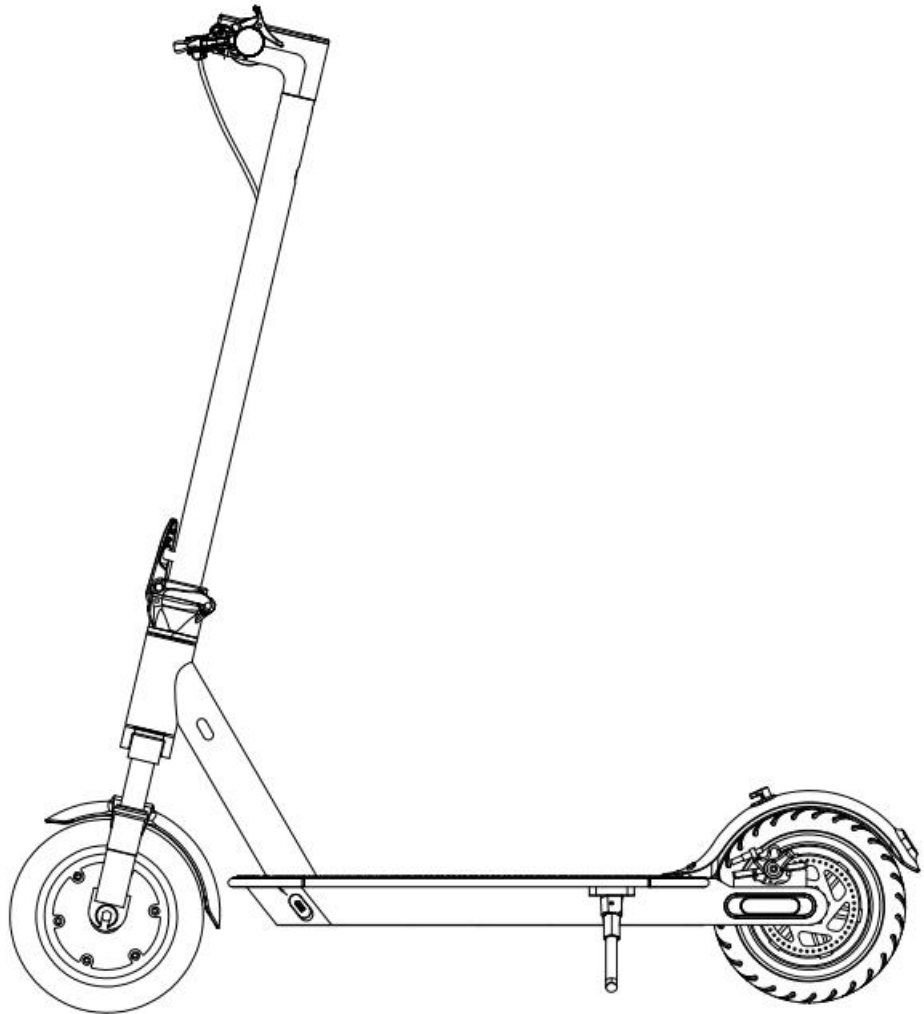

Accessories



Screws x 4



Hex Wrench

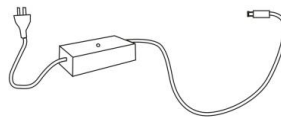

Charging Adapter x 1



Gas-filled extension tube

## 2 Functions

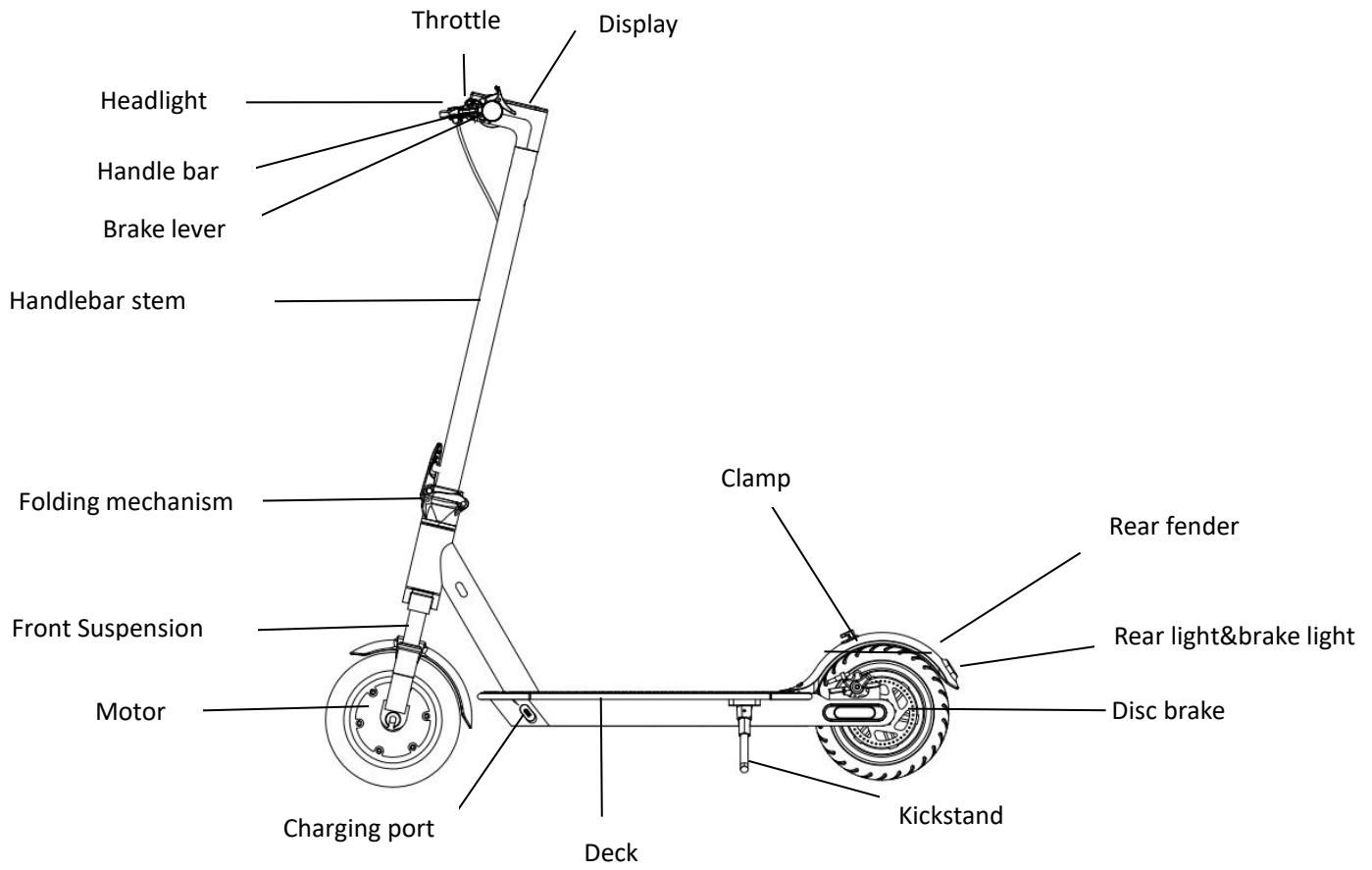

### Display

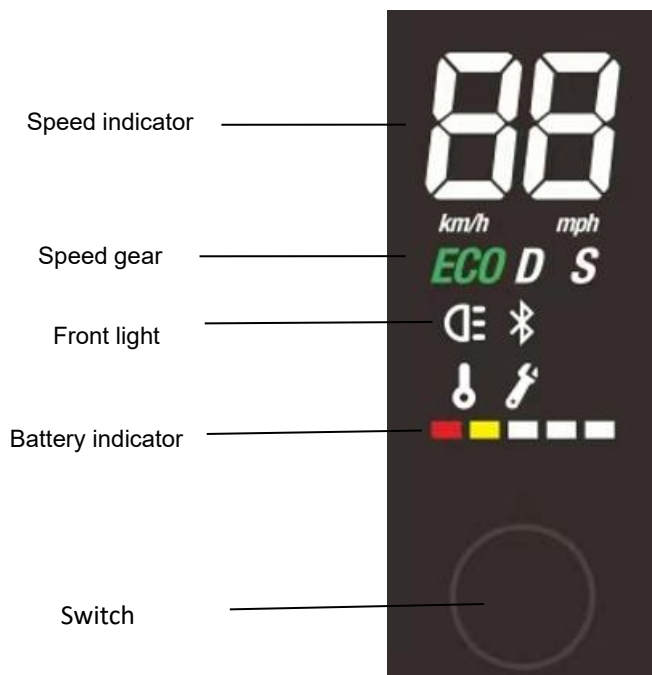

1. **Turn on/off:** Hold down the switch for 3 seconds to power the scooter on/off.
2. **Light Operation:** When the scooter is powered on, press the switch twice to activate the light, and press it twice again to deactivate it.
3. **To select the speed gear:** quick press the switch once. The different gears with their corresponding speeds are listed in the table as below:

Speed gear	Speed range
ECO	0-6 km/h
D	7-15km/h
S	16-20km/h

4. **Battery Indicator:** There are a total of 5 LEDs to display the battery level. When the scooter is fully charged, all 5 LEDs will be illuminated. Please recharge the scooter immediately if only 2 LEDs are illuminated.
5. **Press the brake lever:** the brake light will flashing.
6. **Auto cruise control:** Speed Cruise activated automatically after keeping the same speed for 10 seconds, then you can release the throttle; press brake lever or press again the throttle, scooter returns back to manual mode.
7. **Auto Power off:** After 10mins without any operation, it will be powered off automatically.

### 3 Assembling

- 1) Lift the handlebar stem and lock it into place. Then put the kickstand down(Be careful with the handlebar).

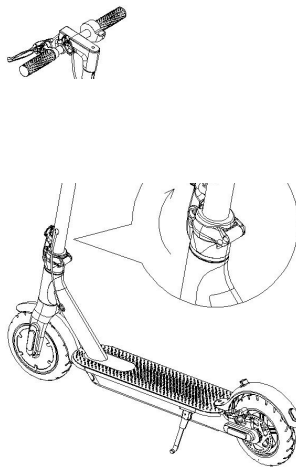

- 2) Attach the handlebar to the stem. Note: take care not damaging any cables.

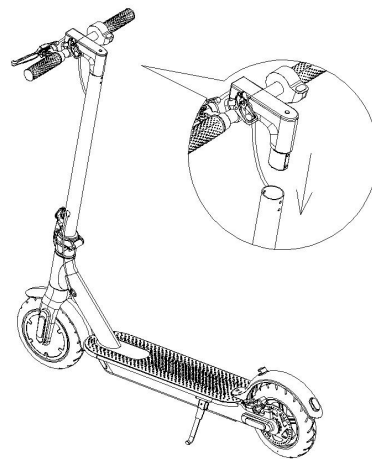

- 3) Use the screws and hex wrench provided to secure the handlebar.

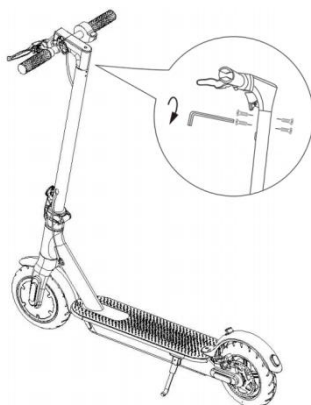

- 4) Once you have completed the installation, turn on the product to verify that all functions are operational.

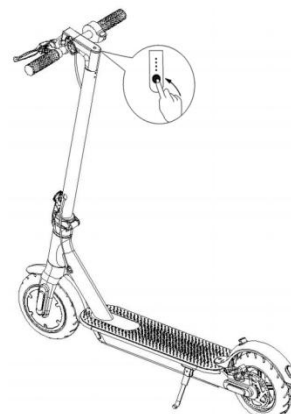

## 4 Charging scooter

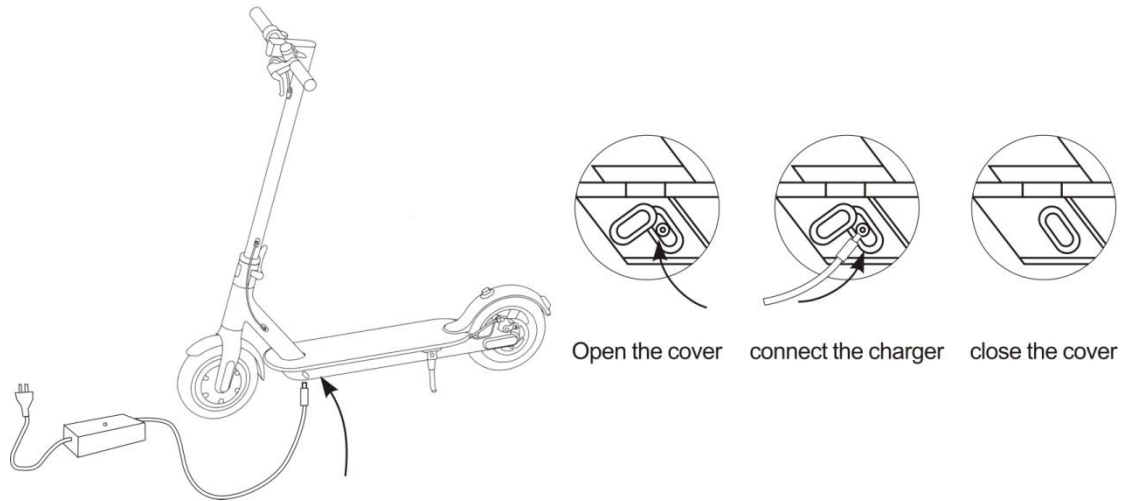

**ATTENTION: The red light on the power supply will turn green when charging is complete.**

## 5 Driving Instructions

1. Wear helmets and knee pads to prevent injuries in the event of any accidents while learning to ride the scooter.

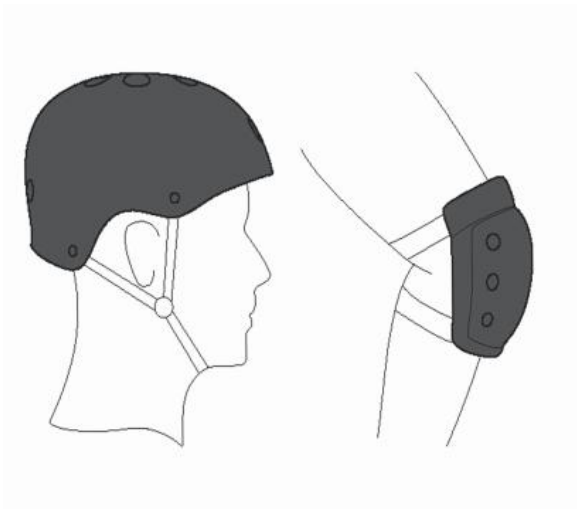

2. Turn on the scooter, and check the battery indicator.

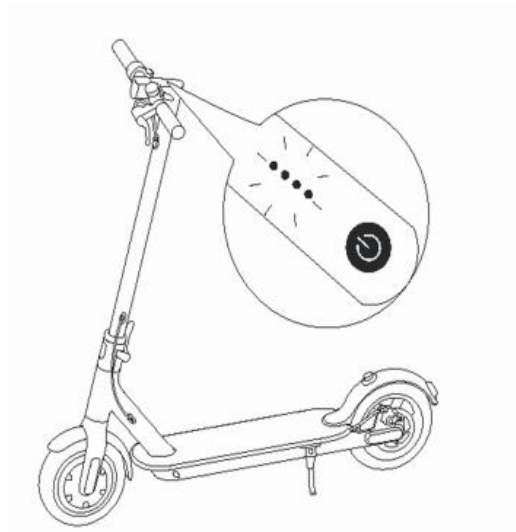

3. Stand on scooter platform with one leg, hit the ground with the other leg.



4. Step onto the scooter with the other leg once the scooter is in motion, then apply pressure to the throttle (only accelerate when the scooter's speed exceeds 3 km/h).

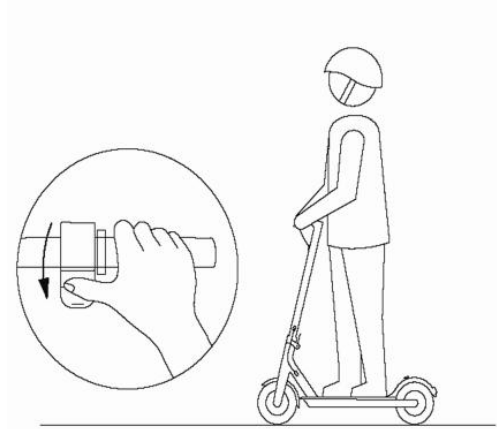

5. Release the throttle to slow down. The energy recovery systems will engage automatically to assist in slowing down. If you need to brake urgently, firmly press the left disc brake lever.

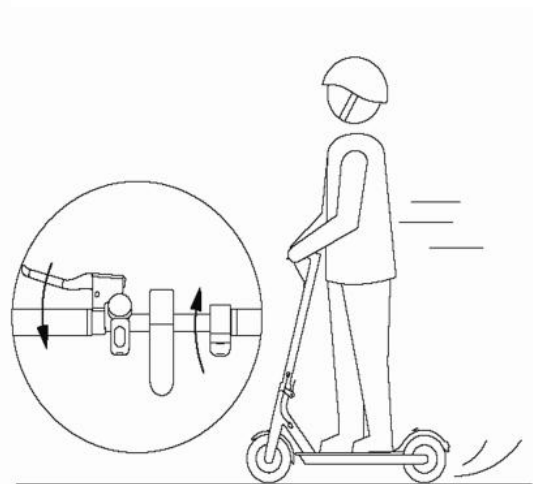

6. Lean your body slightly to the left to turn left, and lean your body slightly to the right to turn right. Additionally, turn the handlebar slowly in the corresponding direction.

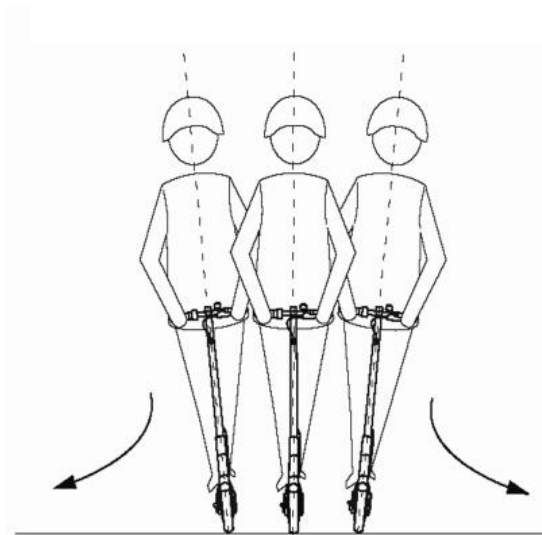

## 6 Safety Instructions



### Avoid safety hazards

- 1 It is not recommended to drive in the rain.
- 2 It is recommended to slightly bend your knees to better adjust to rough roads. If traveling on a rough road, stick to a low speed (5-10 km/h).
- 3 Entering into any room, elevator, etc. Be careful not to be injured by a door frame.
- 4 Please do not increase speed when descending a hill.
- 5 While walking with a scooter, do not press the throttle.
- 6 When driving, it is recommended to go around various obstacles on a road.
7. Please do not hang backpacks and add other heavy objects on handlebars



### Preventing dangerous driving

- 1 Do not leave or park your scooter in the middle of the road; park them at attended places
- 2 It is forbidden to make sharp turns in residential areas with heavy pedestrian traffic
- 3 It is not recommended to drive through puddles deeper than 2cm.
- 4 Never rider a scooter with more than one person or together with a child.
- 5 Do not step on the back of the fender
- 6 Do not touch the disc brake.
- 7 Do not drive without holding onto the handlebars
- 8 Do not ride an electric scooter up or down steps, or attempt to jump over obstacles.



## **Safety Recommendations**

- 1) Electric scooter - It is primarily a recreational device. However, when used in public areas, electric scooters have certain safety risks. For your safety and the safety of others, it is essential to strictly adhere to the instructions outlined in this driving manual
  
- 2) It's important to understand that when riding a scooter in a public place, strict adherence to safety recommendations is necessary. Additionally, keep in mind the potential for collisions resulting from pedestrian or vehicle traffic rule violations, as well as the risk of injury due to improper scooter operation. Similar to other vehicles, higher speeds on electric scooters lead to longer braking distances. Emergency braking on smooth roads may cause the scooter to skid, leading to loss of balance and potential falls. Therefore, it's essential to remain focused while operating the scooter, maintain an appropriate speed, and keep a safe distance from pedestrians and other vehicles. When riding on unfamiliar terrain, maintain focus and adjust your speed accordingly.
  
- 3) While riding scooter, it is important to respect the rights of pedestrians. avoid frightening them, especially children. Reduce your speed while passing by them. If you are moving in the same direction as pedestrians, try to move to the left side as much as possible(for right-hand traffic countries ). If you are moving in the opposite direction, stay to the right and slow down.
  
- 4) Please strictly following your country's road rules while driving, and also strictly follow the rules, set out in the instructions and safety recommendations. Violation of these rules may result in financial expenses, personal injury, traffic accidents, legal disputes, conflicts and other unpleasant situations. Our company does not bear any direct or joint liability.
  
- 5) To avoid injury of others, do not lend electric scooter to others who are unfamiliar with operation it. Prior to lending your scooter to friends or others, provide them with training and ensure they wear appropriate safety gear.
  
- 6) Please inspect the scooter carefully before each use. If you notice any shattered parts, significant decrease in battery life, tire air leaks, signs of excessive wear, unusual sounds when turning, or any other abnormal symptoms, discontinue use of the scooter immediately. Do not use it reluctantly

## 7 Fold and Transportation

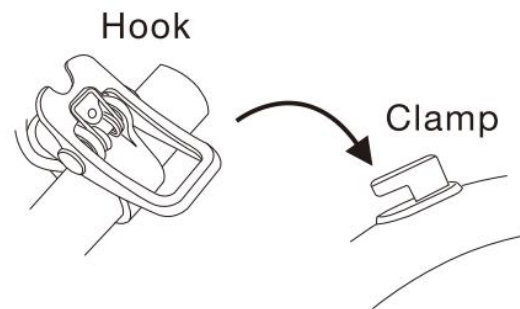
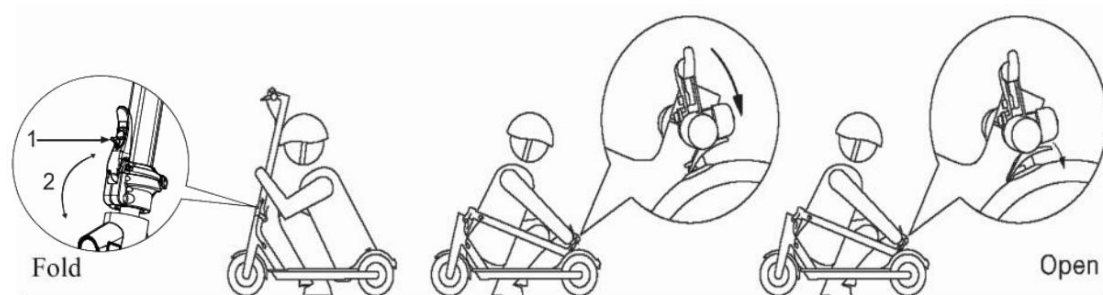

Ensure that the scooter is turned off.

To fold, push upwards on the small button (1) highlighted in the diagram above while simultaneously pulling the larger lever (2) towards you. This action will release the locking mechanism. Then, bend the handlebar stem to hook the clamp on the rear fender.

To unfold, press the hook located on the handlebar, then lift the handlebar stem up to a vertical position and lock the folding mechanism.



Always carry your scooter with one or both hands from the handlebar stem.



Portable rear fenders are prohibited for handling

## 8 Daily Maintenance and Storage

### Clean and store Electric Scooter

If you find any stains on electric scooter housing, use a soft,damp cloth to wipe the vehicle; Y

Warning: Do not use alcohol, petrol, kerosene, or other corrosive solutions, volatile chemical solvents to clean the vehicle. Doing so may cause serious damage to the scooter body and disrupt the structure of internal elements. Do not wash the electric scooter under strong water pressure; ensure the scooter is turned off. Additionally, after charging the vehicle, it is necessary to insert the plug back into the charging connector to prevent electric shock and potential water damage caused by water entering the charging port.

If you are not using the scooter, store it in a dry, cool place, and avoid leaving it outdoors for an extended period. Exposure to sunlight, extremely high temperatures, or very low temperatures can cause rapid aging of the outer body and wheels of the Electric Scooter, or reduce battery life.

### Maintenance of Electric Scooter battery

- 1) Do not use batteries from other brands to avoid potential dangerous situations.
- 2) Do not open or disassemble the battery to prevent electric shock. Avoid contact with metal objects to prevent short circuits, which may result in battery malfunction or user injury.
- 3) It is recommended to use the AC adapter provided in the original configuration of the device to prevent accidents or vehicle fires.
- 4) Improper disposal of used batteries and accumulators can cause severe environmental pollution. Please dispose of batteries in accordance with local laws and avoid disposing of them with food waste. Let's protect the environment together!
- 5) After each use of the device, charge the battery to prolong its service life.

Do not store the scooter battery in rooms where temperatures exceed 50°C or fall below -20°C (for example, do not leave the battery of the Electric Scooter and other batteries in cars under the hot sun during summer). Additionally, do not place the battery near fire, as these actions may lead to battery deterioration, overheating, and even inflammation.

If the scooter is not used within 30 days, it is recommended to charge the battery and store the device in a cool, dry place. Every 60 days, it's necessary to charge the battery again; otherwise, there is a likelihood of battery failure, which is not covered by warranty services. Avoid fully discharging the device as it will extend the battery life. When using the device at normal room temperature, the battery will be able to travel a much greater distance, and its performance will be better. However, if you use the scooter at temperatures below 0°C, the vehicle's performance and range decrease. At -20°C, the traveled distance is less or even down 50% than the scooter would achieve in optimal conditions.

As temperatures rise, the traveled distance by the vehicle will also increase. You can check the remaining distance in the Application.

Note: A fully charged scooter has about 120-180 days of standby time. The battery contains a smart chip that stores information about its charging and discharging cycles. If you do not charge the battery for an extended period, it can cause serious damage, for which it is impossible to charge the device again. This type of damage is not covered by the free warranty service. (Caution: Do not disassemble the device by unauthorized individuals, as there is a risk of electric shock or serious injury due to a short circuit.)

### Adjusting the disc brake

If the brake is too tight, use the supplied hex wrench to loosen the screws on the caliper. Then, slightly pull back the brake cable to shorten its length, and tighten the screws afterwards. If the brake is too loose, loosen the screws slightly and pull out the brake cable to lengthen it. Finally, tighten the screws once adjustments are made.

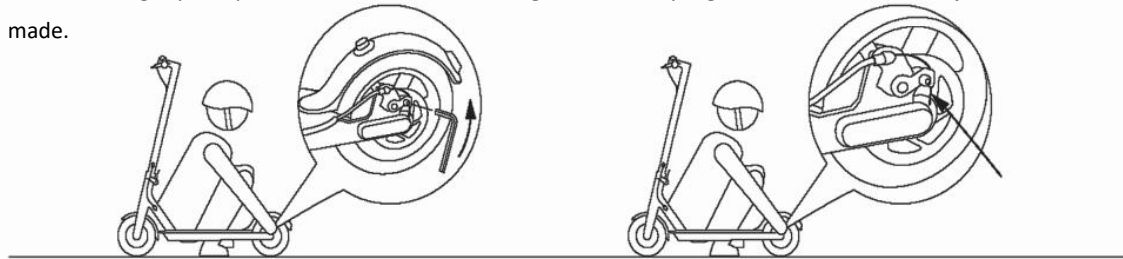

### Adjusting the handle bar

If the handlebar and its stem sway during riding, use the supplied hex wrench to tighten the screws on the folding mechanism.

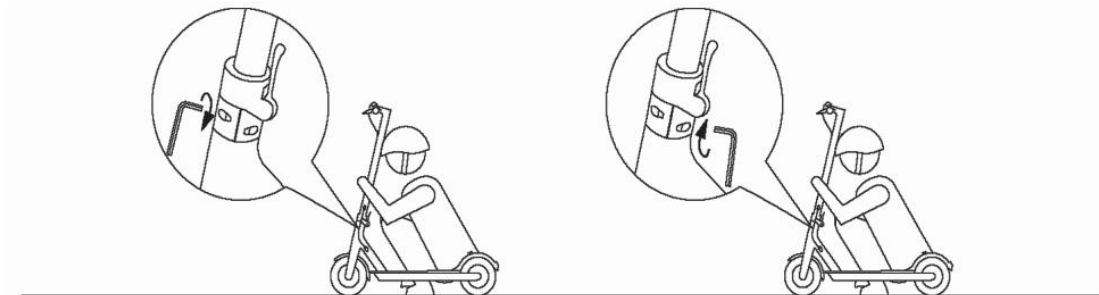

### Using a connecting pipe to pump wheels

If the wheel of the Electric Scooter deflates, connect a connecting pipe to the wheel nipple to pump it. First, remove the cap from the pin, then tighten the fitting, and finally, begin pumping the wheel.

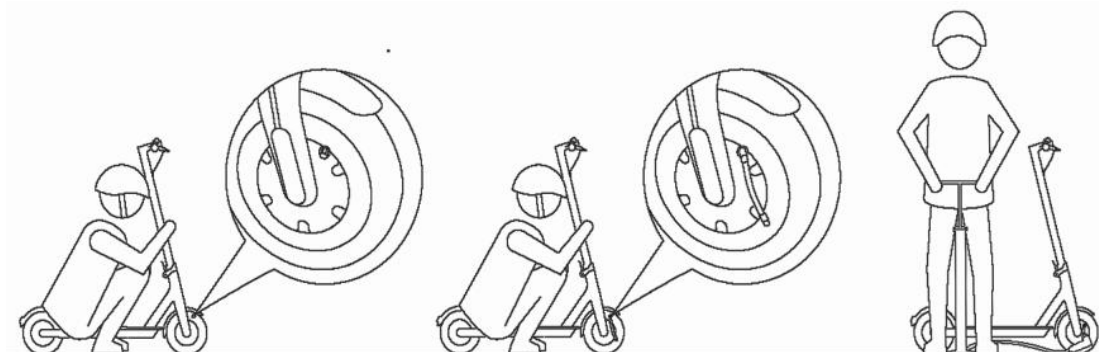

## 9 Remove the outer and inner tires

**Note: Crowbars not included, and should be purchased separately.**

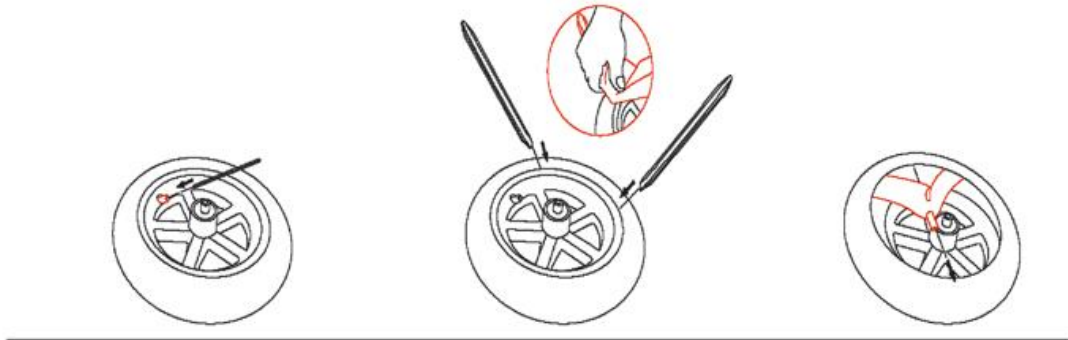

1. Deflate the inner tire first. Use a tool to press the core rod in the air valve so that air is discharged from the inner tire. Then, with another hand, forcibly pinch the tire at different places to release more air.
2. Select a position far from the air valve on the outer tire, use two crowbars to pry up the outer tire by about 1/6 of the circumference, and forcibly separate one side of the outer tire from the hub.
3. Find the air valve and pull it out of the air valve hole in the hub. To pull out the air valve more conveniently, hold the air valve of the inner tire, and pull the outer tire outwards slowly to prevent damage to the inner tire. Remove the inner tire from the position of air valve in sequence and separate the inner tire finally.

**Note: Wrap the pointed end of the crowbar with fiber cloth to avoid damaging the inner tire and the hub's coating.**

### Install the outer and inner tires

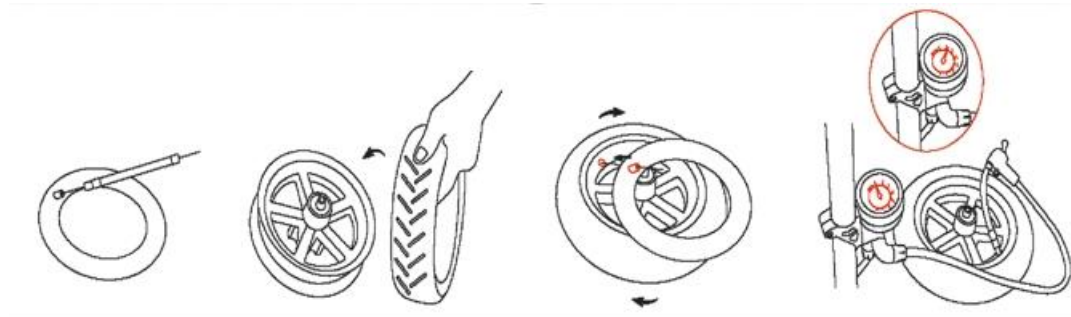

1. Fill a small amount of air into the deflated inner tire until the inner tire is just bulged to appear round.
2. Place the hub on top of a desk. Pay attention to the direction when installing the outer tire. There is an arrow on the outer tire, and it must align with the forward direction of the wheel. Hold the hub with one hand and use the other hand to insert one side of the outer tire into the hub groove.
3. Insert the air valve of the inner tire into the air valve hole. Insert the inner tire into the outer tire clockwise and in sequence, ensuring that the air valve does not tilt. Then, insert the other side of the outer tire into the hub groove. Finally, use a crowbar to install the remaining tire lips into the hub groove. After installation, pinch the outer tire to check if the inner tire is pressed by the tire lips of the outer tire
4. Inflate the inner tire to 15-20 PSI, and check the safety lines on both sides of the outer tire. Ensure that the distances from the safety lines to the hub edge are consistent.
5. Finally, inflate the inner tire to 45-50 PSI. Tighten the air valve cap. With that, the tire assembly is completed.

**Note: Wrap the pointed end of the crowbar with fiber cloth to prevent damage to the inner tire and the coating of the hub.**

## 10 Specifications

Operating Parameters	Name	Parameters
<b>Dimensions</b>	Unfold: Length x Width x Height	108*47.5*120cm
	Folded: Length x Width x Height	108*47.5*55.5cm
<b>Weight</b>	Net Weight	13kg
	Gross weight	15kg
<b>Conditions</b>	Max load	120kg
	Age	16-50 years old
	Height	120-200cm
<b>Main Parameters</b>	Max speed	20 km/h ( varies according to soil and weight)
	Range	25-30km( varies according to soil, speed and weight)
	Maximum slope	About 11%
	Suitable area	Cement, asphalt and muddy roads, platforms less than 1cm, surface with cracks less than 2cm wide
	Operating temperature range	-10-40°C
	Temperature of storage	-20-45°C
	Waterproof level	IPX5
<b>Battery Parameters</b>	Rated voltages(VDC)	36V
	Max voltage of charging(VDC)	42V
	Rated power	280.8Wh
	Smart battery management system	Abnormal temperature management, short circuit, automatic back-up, over-voltage, double overload, double protection
<b>Motor Parameters</b>	Rated power	250W
<b>Charger Parameters</b>	Rated power	63W
	Rated input voltage(VAC)	100-240V
	Rated output voltage(VDC)	42V
	Rated current	1.5A
	Charging time(h)	About 5-6 hours



Made in China